



TALKAPHONE

WEBS-MT/R SERIES EMERGENCY PHONE TOWER

TALKAPHONE'S WEBS-MT/R EMERGENCY PHONE TOWER IS AN IDEAL SECURITY SOLUTION FOR REMOTE AND HIGH-RISK AREAS WHERE WIDE-AREA AUDIO BROADCAST IS DESIRED. THE UNIT CAN BE USED AS PART OF THE TALK-A-PHONE'S WIDE-AREA EMERGENCY BROADCAST SYSTEM (WEBS®) TO NOTIFY LARGE MASSES OF PEOPLE OF AN EVENT WITH AN INTELLIGENT MESSAGE. SURVEILLANCE AND DAY/NIGHT CHARGE OPTIONS.

FEATURES

- Send live or prerecorded audio messages through the bAlert Mass Notification platform
- Concealed high-power speakers provide 360° coverage, and separate volume controls for each direction
- WEBS-MT/R tower offers contemporary architectural styling and even greater visibility than standard towers
- Attention-getting LED Blue Light is included and mounted atop the unit. The LED Blue Light is continuously lit and flashes for duration of a call when "EMERGENCY" button is pressed.
- LED Blue Light is housed in a protective polycarbonate housing (except for OP4)
- Emergency Phone faceplate is illuminated at all times by an LED Panel Light
- Vandal-resistant structure and coating designed to resist extreme weather conditions
- A variety of signage, graphics, and color choices are available
- Easily mount any Talkaphone VOIP-500 or VOIP-600 Series into the unit (sold separately).
- ADA Compliant



FEATURES

	WEBS-MT/R Radius Emergency Phone Tower with WEBS®	WEBS-MT/R-OP2 Radius Emergency Phone Tower with WEBS® and Provisions for a Fixed Camera	WEBS-MT/R-OP4 Radius Emergency Phone Tower with Camera Arm and WEBS®
			
Construction:	0.25 in. steel	0.25 in. steel	0.25 in. steel
Dimensions (WxDxH):	12.8 x 11.0 x 124.0 in. (324 x 280 x 3150 mm) with 2 in. radius corners	12.8 x 11.0 x 162.0 in. (324 x 280 x 4115 mm) with 2 in. radius corners (height includes arm and strobe)	12.8 x 11.0 x 162.0 in. (324 x 280 x 4115 mm) with 2 in. radius corners (height includes arm and strobe)
Weight:	430 lbs. (195 kg)	475 lbs. (215 kg)	485 lbs. (220 kg)
Coating:	High-gloss, multi-layer, corrosion-inhibitive system with resistance to UV-fade and graffiti protection	High-gloss, multi-layer, corrosion-inhibitive system with resistance to UV-fade and graffiti protection	High-gloss, multi-layer, corrosion-inhibitive system with resistance to UV-fade and graffiti protection
Colors:	Safety Blue is standard. Available in custom colors.	Safety Blue is standard. Available in custom colors.	Safety Blue is standard. Available in custom colors.
Signage:	3.25 in. high reflective white "EMERGENCY" lettering with wide-angle visibility is standard. Available in custom colors, lettering and graphics.	3.25 in. high reflective white "EMERGENCY" lettering with wide-angle visibility is standard. Available in custom colors, lettering and graphics.	3.25 in. high reflective white "EMERGENCY" lettering with wide-angle visibility is standard. Available in custom colors, lettering and graphics.
Audio Broadcast:	Four 40 watt speakers, 123 dBA @ 1 meter	Four 40 watt speakers, 123 dBA @ 1 meter	Four 40 watt speakers, 123 dBA @ 1 meter
Lighting:	LED Blue Light: 209 lumens peak, 78 flashes per minute, 70% of initial lumens after 50,000 hours of operation LED Panel Light: Ultra bright LEDs, 50,000 hour lifetime	LED Blue Light: 209 lumens peak, 78 flashes per minute, 70% of initial lumens after 50,000 hours of operation LED Panel Light: Ultra bright LEDs, 50,000 hour lifetime	LED Blue Light: 209 lumens peak, 78 flashes per minute, 70% of initial lumens after 50,000 hours of operation LED Panel Light: Ultra bright LEDs, 50,000 hour lifetime
Camera Ready:	N/A	Includes provision for an internal fixed camera (not included) located directly above the call station	Includes 1.5-inch NPT for attachment of one (1) dome camera (camera not included)
Power:	Maximum total 130 watts, 110-240VAC/12VDC	Maximum total 130 watts, 110-240VAC/12VDC	Maximum total 140 watts, 110-240VAC/12VDC
Mounting:	Mounts into concrete foundation using included hardware (shipped in advance)	Mounts into concrete foundation using included hardware (shipped in advance)	Mounts into concrete foundation using included hardware (shipped in advance)
Warranty:	5-year warranty on tower (2-year warranty on electronics)	5-year warranty on tower (2-year warranty on electronics)	5-year warranty on tower (2-year warranty on electronics)
Approvals:	ETL Recognized Component -- Conforms to UL Standards 60950-1 and 60950-22. Certified to CSA Standard C22.2 Nos. 60950-1 and 60950-22.		



DIMENSIONAL DRAWING

All dimensions are in inches and are provided for reference only.

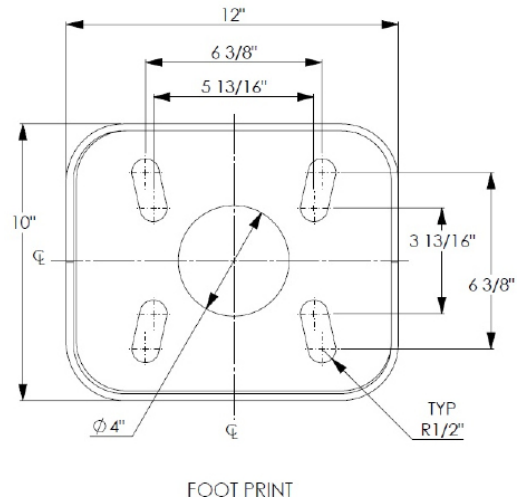
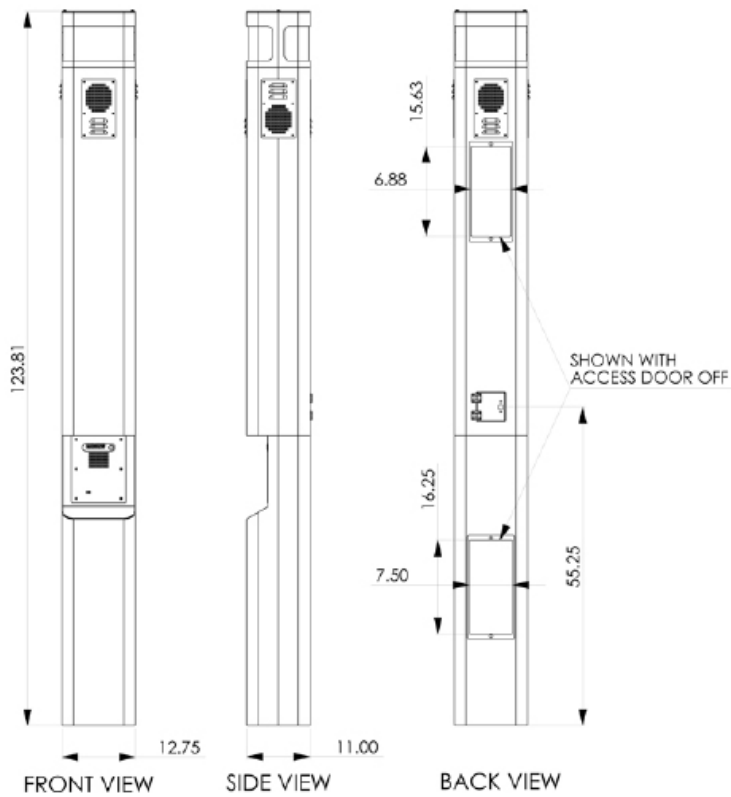

Options

Parking Deck Mounting Kit:

Order model ETP-PDMK-4 to mount on pre-poured parking deck.

Automated External Defibrillator (AED)

Add to Model:	Description:
AED	Secure, recessed AED compartment with lockable door
HTR	Thermostatically controlled heater for AED compartment



TALKAPHONE

THE LEADERS IN SECURITY AND LIFE SAFETY COMMUNICATIONS

7530 North Natchez Avenue
Niles, Illinois 60714

Tel: 773-539-1100
Email: info@talkaphone.com
Web: www.talkaphone.com

Terms of Use and Limited Warranty

This Product includes intellectual property and proprietary rights owned by Talk-A-Phone, LLC and/or its licensors. Your use of this Product confirms your agreement that Talk-A-Phone, LLC and/or its licensors retain all right, title and interest in and to all such property; that your rights are to access and use the Product for your internal business use only; that all Product elements will be maintained as confidential; and that the Product may not be rented, leased or lent to third parties, reverse engineered, decompiled or disassembled, or otherwise used for any purpose other than as an access device for your premises. Talk-A-Phone, LLC warrants Talk-A-Phone Emergency Phone, Call Station, and Wide-Area Emergency Broadcast System equipment against any defects in material and workmanship, under normal use, for a period of twenty-four (24) months from date of installation, provided that Talk-A-Phone receives a completed "Installation Certification" certifying the date on which the system has been installed. An "Installation Certification" card is enclosed with every unit. In the event that no "Installation Certification" is received by Talk-A-Phone, the twenty-four (24) months will commence on the date of shipment by Talk-A-Phone. Warranty period for the metal elements of models in the GP Series Pedestals, MT Series Towers, MTE Series Towers, MT/R Series Towers, PM Series Pedestals, SM Series Surface Mounts, Via Series Mounts, and WM Series Wall Mounts is five (5) years, under the same terms and conditions. Warranty period for Area of Rescue Products is sixty (60) months, under the same terms and conditions. Warranty period for Intercommunication Products is twelve (12) months, under the same terms and conditions. If the Product is found by Talk-A-Phone to be defective within the warranty period, Talk-A-Phone's only obligation, and your exclusive remedy, is for the repair or replacement of any defective parts, provided that the Product is returned to us at 7530 N. Natchez Ave., Niles, IL 60714. Talk-A-Phone shall have no obligation to furnish or pay for the labor of any third parties or bear the expense of shipping defective Products for repair. In no event shall Talk-A-Phone or its licensors or suppliers be liable for any form of exemplary or punitive damages, or any special, indirect or consequential damages. TALK-A-PHONE EXPRESSLY DISCLAIMS ALL OTHER WARRANTIES, WHETHER EXPRESS, IMPLIED OR STATUTORY, INCLUDING BUT NOT LIMITED TO THE IMPLIED WARRANTIES OF MERCHANTABILITY OR FITNESS FOR A PARTICULAR PURPOSE. In no event shall Talk-A-Phone or its licensors or suppliers be liable for any form of exemplary or punitive damages, or any special, indirect or consequential damages. Your use of this Product constitutes your agreement to all of the foregoing terms.

THIS WARRANTY GIVES YOU SPECIFIC LEGAL RIGHTS AND YOU MAY ALSO HAVE OTHER RIGHTS WHICH VARY FROM STATE TO STATE. Further information is available at talkaphone.com/legal Copyright 2021 Talk-A-Phone, LLC All Rights Reserved - Rev. 8/17/2021