

EMERGENCY PHONE MOUNTS

ETP-PMD – Dual Faceplate Pedestal Mount

Description

Free standing Dual Faceplate Stainless Steel Pedestal Mount allows an Emergency/Information or Access phone to be mounted practically anywhere. An additional faceplate allows a card reader, camera, directory or other device to be mounted above the phone.

Features

- Constructed of vandal resistant 3/16" stainless steel with slanted top
- Pedestal features 2" radius corners, offering contemporary architectural styling
- Easily mount any 400-Series or 500-Series Talk-A-Phone Emergency/Information Phone
- Faceplates are lit at all times by compact concealed light
- Secondary plate available in stainless or aluminum for mounting directories, cameras, card readers and other devices
- Available with optional wording on sides

Specifications

Dimensions:	12.0(305) W x 8.0(203) D x 60.1(1527) H in(mm)
Weight:	130 lbs. (59.0 kg)
Construction:	3/16" (4.8mm) brushed stainless steel
Lettering:	3.25" (82.5mm) high reflective letters, available in many colors and wordings
Lighting:	Ultra bright LEDs, 50,000 hour lifetime
Power:	Faceplate Light: 1.2 watts, 12-120VAC/DC Emergency Phone: ETP-400 Series Phones (sold separately), powered by a phone line; VOIP-500 Series Phones (sold separately), powered by 12VDC, 24VAC/DC or PoE
Mounting:	Mounts into concrete foundation using included hardware (shipped in advance)



ETP-PMD-SS shown with ETP-400K and 25141 blank stainless faceplate

Options

ETP-PMD-SS Configuration	Emergency Phone	Wireless Option	Faceplate Camera Option	Pedestal Options
Analog Connectivity	400 Series Analog Phone	ETP-CI (cellular)	Add "-OP3" to any Emergency/Information Phone for an integrated color camera mounted behind the faceplate	Painted Option: Model ETP-PMD is made of 1/4" steel with multi-coat rust inhibitive coating Single Opening Option: Model ETP-PM-SS (12"W x 8"D x 48"H) is 4 feet tall and has room for one hands-free phone or other device (wireless option)
IP Connectivity	500 Series VoIP Phone	VOIP-RF (2.4GHz radio frequency)		

Copyright 2010 Talk-A-Phone Co. All rights reserved.

ETP-PMD-SS – Dual Faceplate Stainless Steel Pedestal Mount

Accessories

Blank Stainless Plate: Model **25141** is a blank stainless faceplate for mounting additional devices
 Blank Aluminum Plate: Model **25155** is a blank aluminum faceplate for mounting additional devices

Dimensions

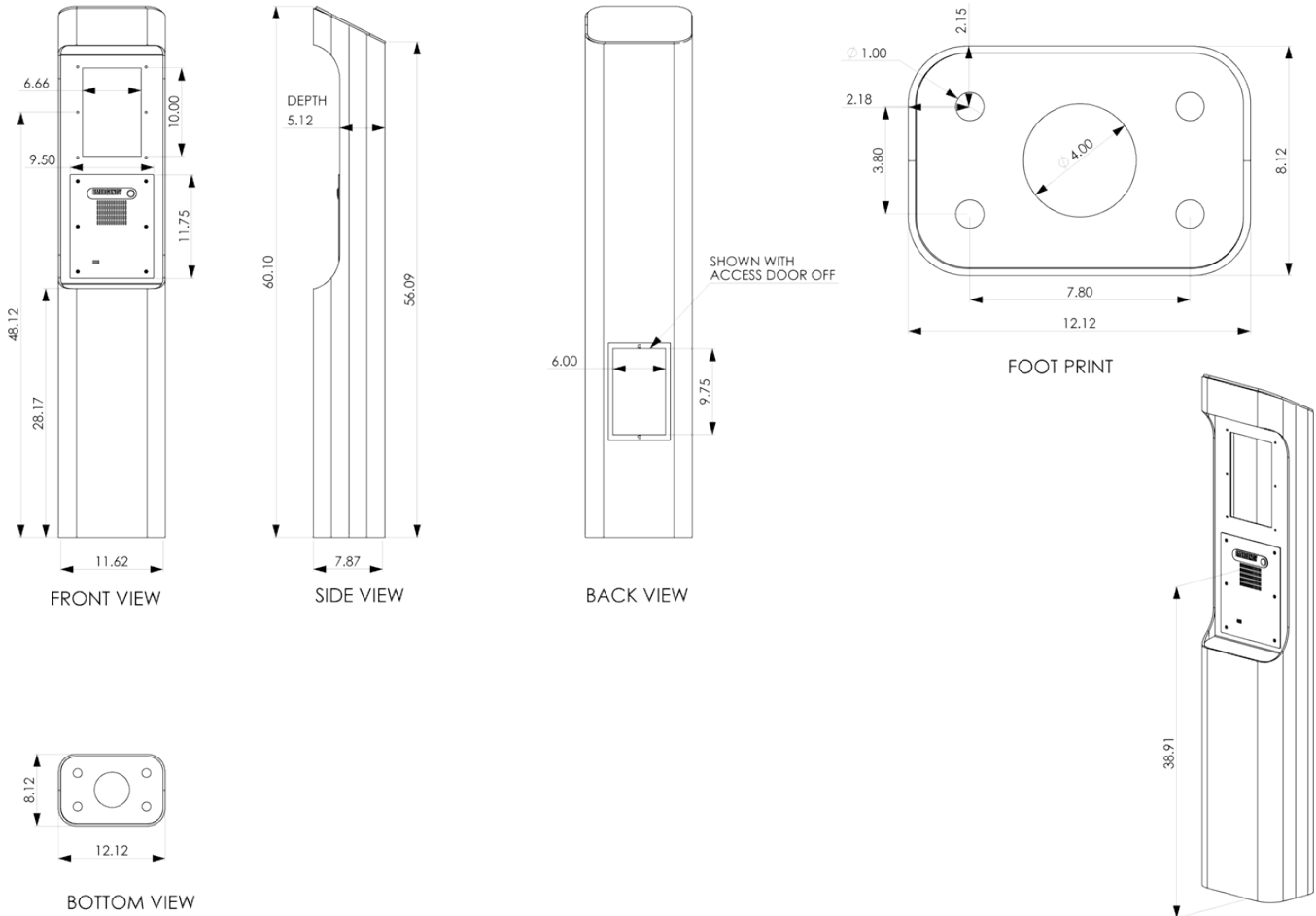

All dimensions are in inches

Copyright 2010 Talk-A-Phone Co. All rights reserved.

Talk-A-Phone Co. • 7530 North Natchez Avenue • Niles, Illinois 60714-3804
 Phone 773.539.1100 • Fax 773.539.1241 • info@talkaphone.com • www.talkaphone.com
 All prices and specifications are subject to change without notice.
 Talk-A-Phone, Talk-A-Lert, Scream Alert and WEBS are registered trademarks of Talk-A-Phone Co.