

FRONT VIEW

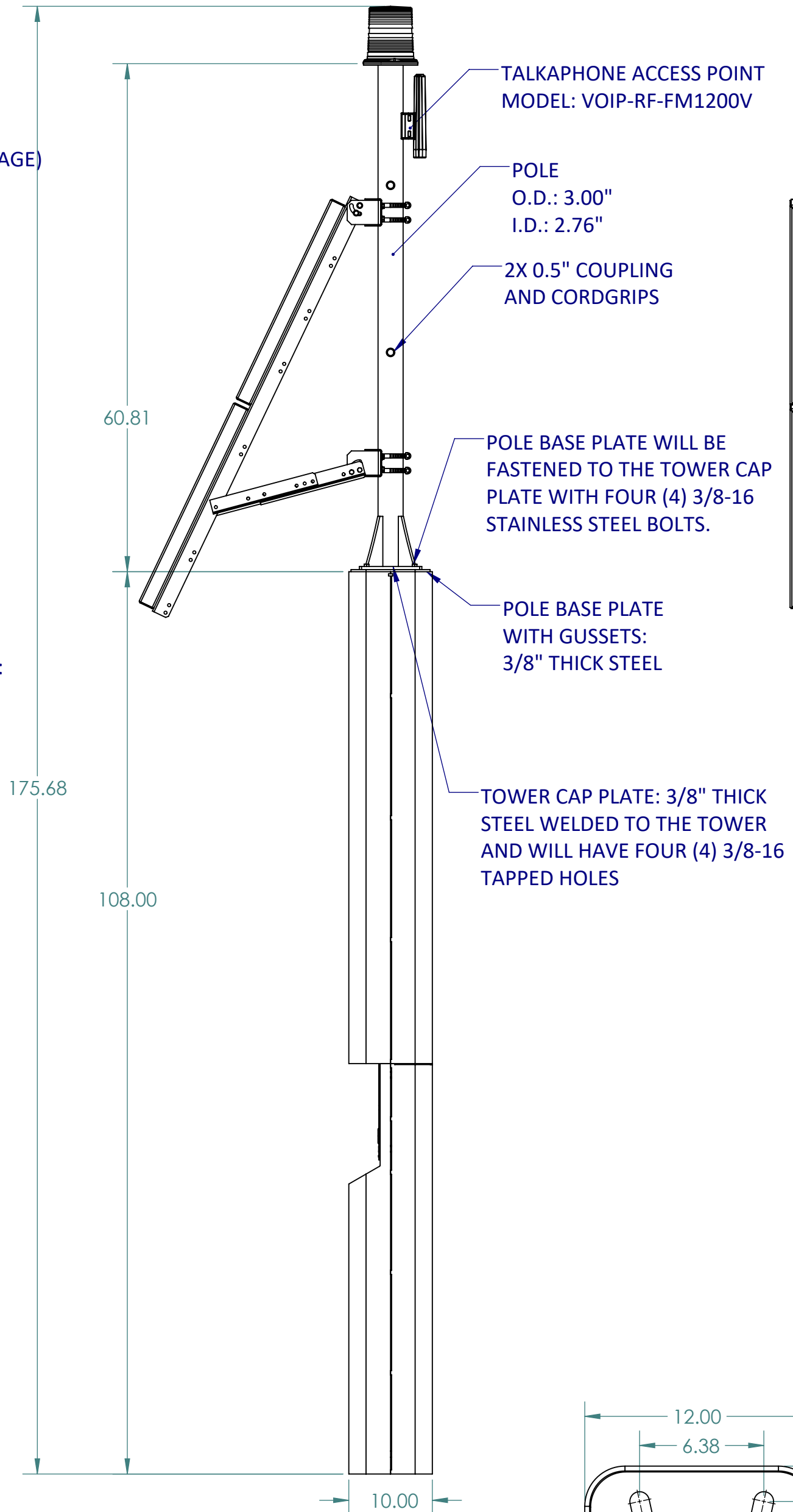

SIDE VIEW

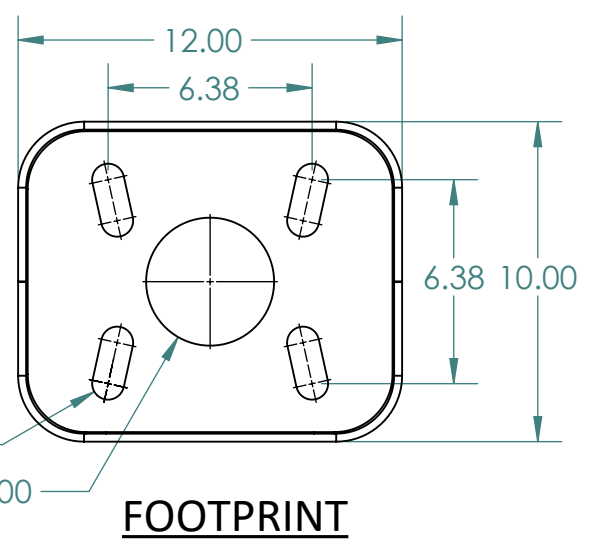

FOOTPRINT

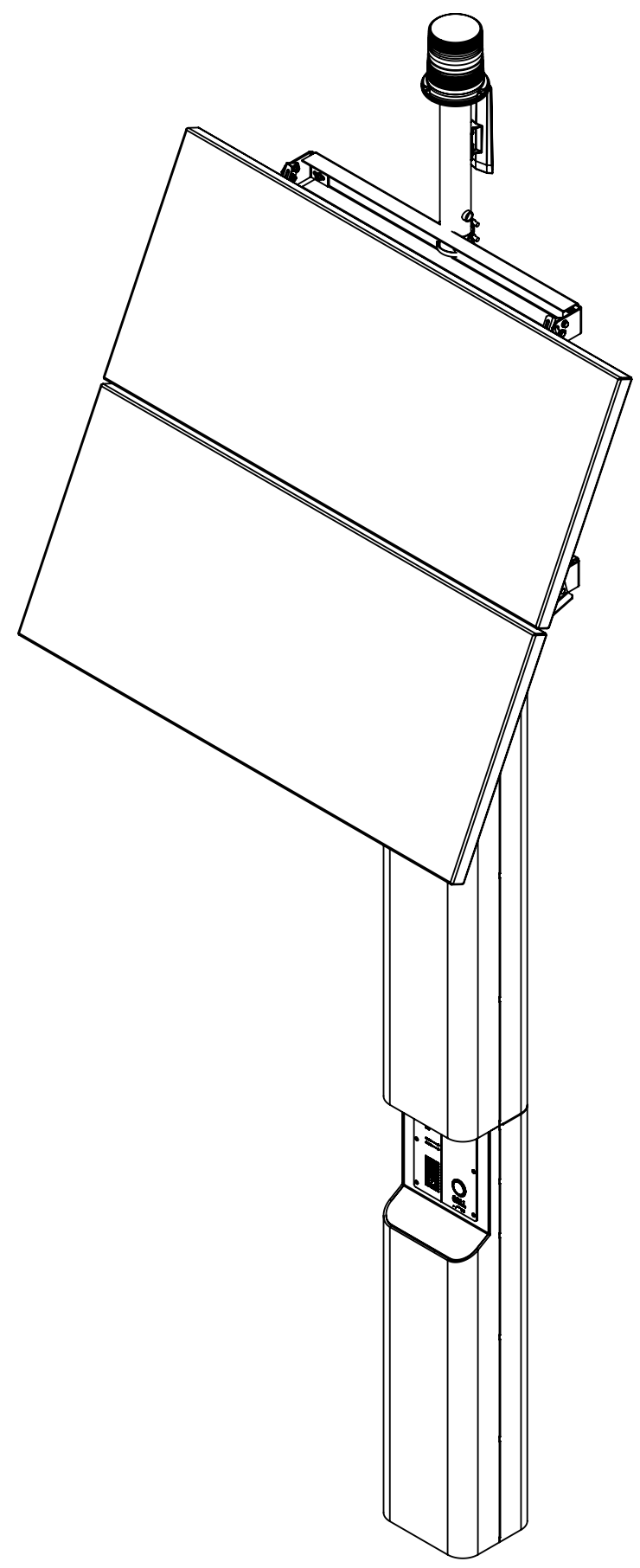
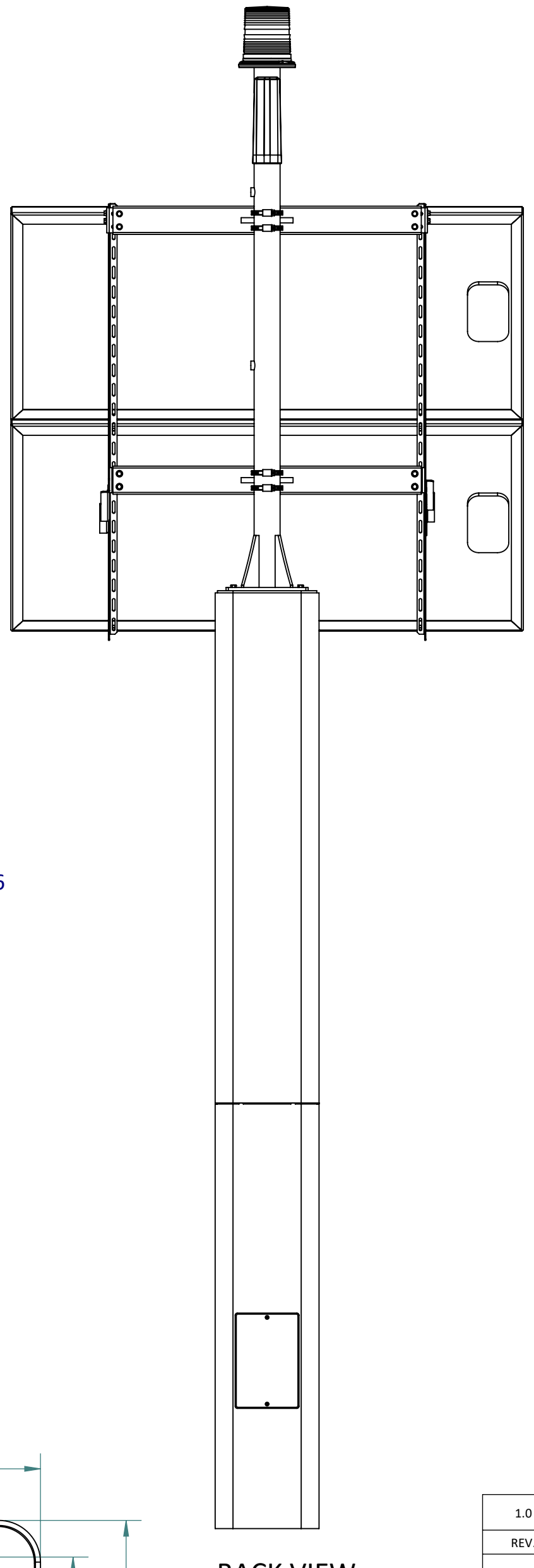

+ CUSTOMER APPROVAL:

COMPANY/ ORGANIZATION	APPROVAL SIGNATURE
DATE	NAME

1.0	PRELIMINARY RELEASE	10/20/2016	M OBAL
REV.	DESCRIPTION	DATE	APPROVED
REVISIONS			
DRAWN	NAME	DATE	
CHECKED	M OBAL	10/20/2016	
ENG APPR.	K PATEL	10/21/2016	
MFG APPR.			
Q.A.			
COMMENTS:			
 TALKAPHONE TALK-A-PHONE CO. 7530 N. NATCHEZ AVE. NILES, IL 60714 WWW.TALKAPHONE.COM		DWG. NO. SIZE PART NO. ETP-MT/R-SOLAR60 REV C DWG. TITLE: ETP-MT/R-SOLAR SERIES 1.0 SCALE: 1:24 WEIGHT: SHEET 1 OF 1	

FINISH

PROPRIETARY AND CONFIDENTIAL
THE INFORMATION CONTAINED IN THIS
DRAWING IS THE SOLE PROPERTY OF
TALK-A-PHONE COMPANY. ANY
REPRODUCTION IN PART OR AS A WHOLE
WITHOUT THE WRITTEN PERMISSION OF
TALK-A-PHONE COMPANY IS PROHIBITED.